

PORTABLE EQUIPMENT FOR METAL FORMING AND CUTTING **FM-30**

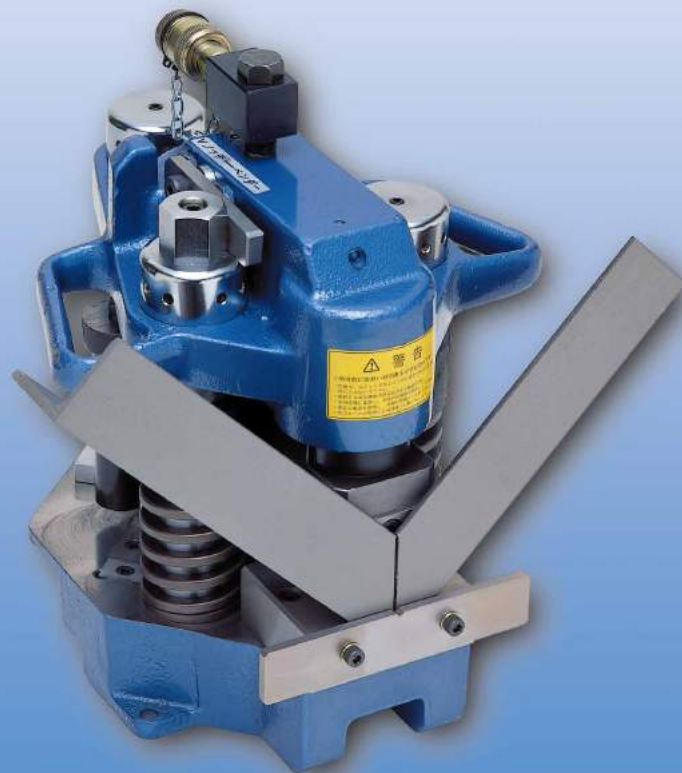

Die sets exchange is unnecessary

- 90° V-NOTCH CUTTING
- 45° CORNER CUTTING

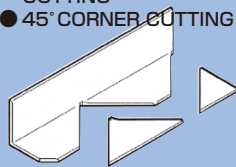

- 45° ANGLE BENDING

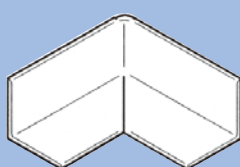

- 90° CORNER CUTTING

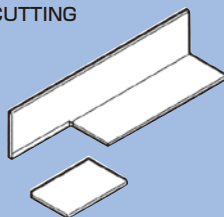

- EDGE CUTTING

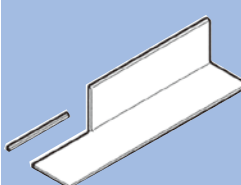

- PUNCHING

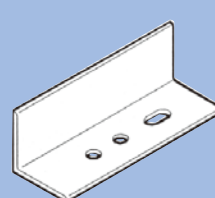



FM-30 is a forming machine with outstanding workability, unnecessary for die replacement. It is a compact, high-performance machine that can cut and bend stainless steel angle material of 75 mm (width) x 6 mm (thickness).

FM-30

■ **It has the greatest processing performance among the same category.**

This is a force of 23 tons, making it possible to process stainless angle material (75 mm x t 6mm) only with the standard set.

■ **Die exchange is unnecessary.**

Die of a V notch (corner cut) and a bender are built in, so you do not need to replace the die.

■ **Double cylinder system with a changeover lever.**

By adopting the double cylinder system, it is possible to smoothly perform a series of work including V notch, 90°, 45° corner cutting, and bending process by simply switching the changeover lever.

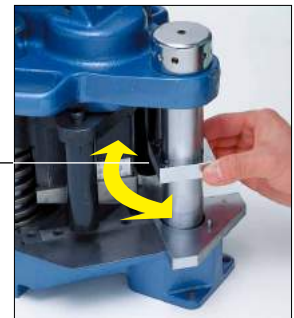
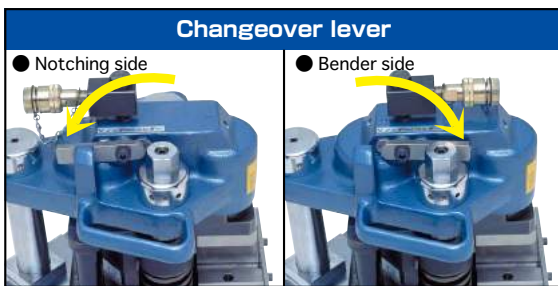

■ **Easy positioning with clamp base.**

Adjust the clamp base according to the thickness of the angle material(3 mm to 6 mm) , so when you process angle bar, you can make alignment easier.

■ **Compactness and portability.**

Since the main unit and the hydraulic unit are separate, it is easy to carry to the work site.

■ **Wide choice of hydraulic pumps.**

Depending on the frequency of operation, you can choose a high-speed pump (450 W Deluxe type) or a super light type pump (350 W standard type).

You can also use your own hydraulic pump unit. In that case, the pressure should be 70 Mpa and the hydraulic couplers should be the same kind.



Standard processing time	Standard type	Deluxe type
Time required Notchig of 65 x 65 x t6mm	UP-35RH-FL 13 sec.	UP-45SVG-FL 7.5 sec.

■ **Hydraulic pump works with 100V, 220V and 230V.**

**Without die exchange, the following 5 + 1 types of angle processing are possible.
(Punching need an optional unit.)**

90° V notching / 45° corner cutting

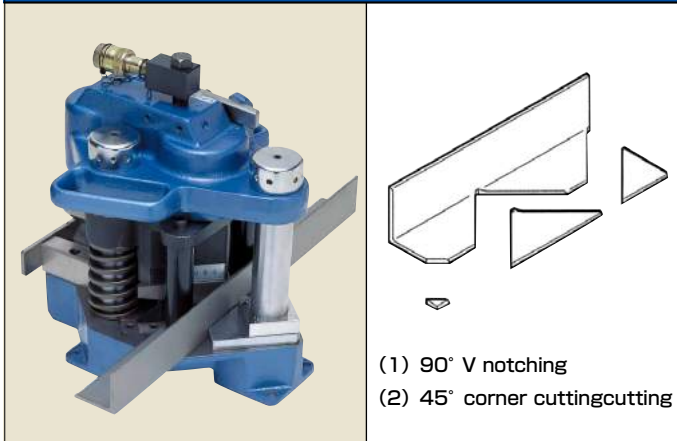

Angle bending

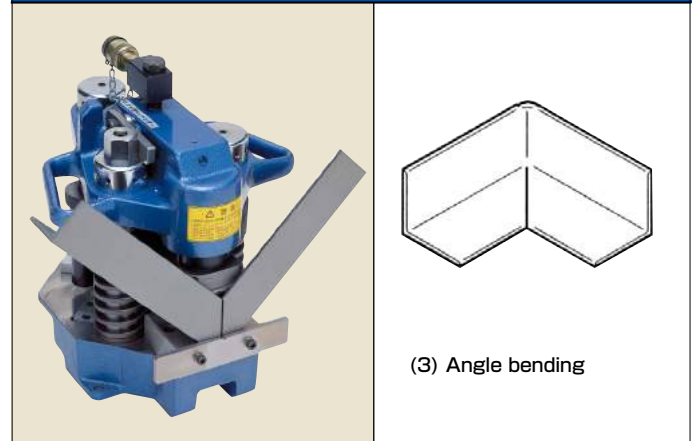

90° corner cutting

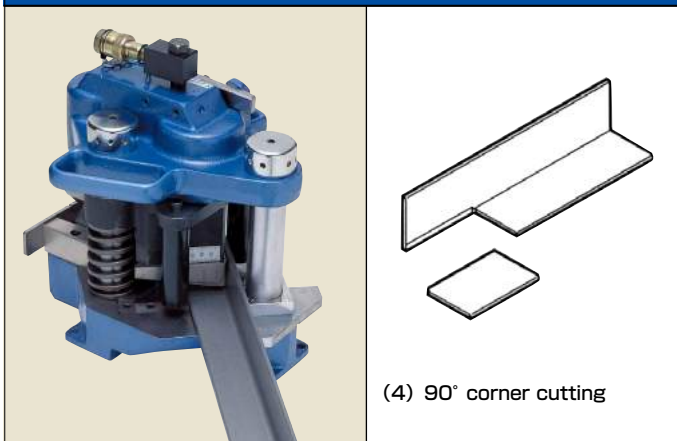

Edge cutting

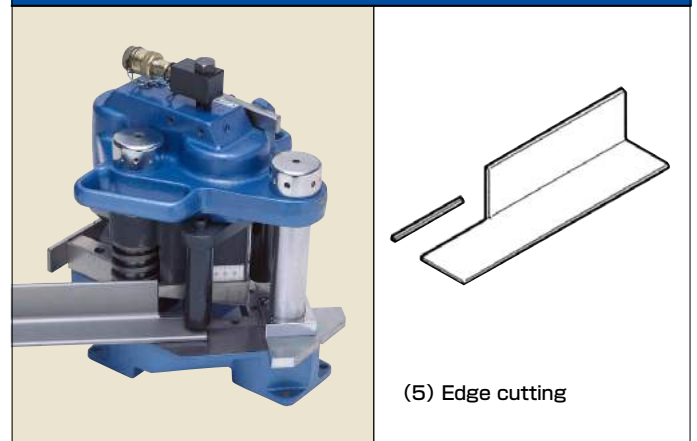

Punching (option)

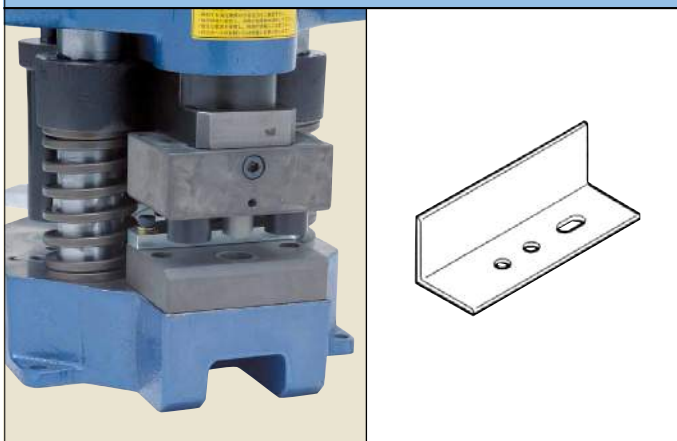

■ Optional punching unit

Type	Name of article
P-75	punching die set
P-11	φ 11mm punch & die
P-11 (L)	11 × 16.5mm oblong punch & die
P-13	φ 13mm punch & die
P-14	φ 14mm punch & die
P-14 (L)	14 × 18mm oblong punch & die
P-15	φ 15mm punch & die
P-18	φ 18mm punch & die

■ Dimensions / Specifications

(mm)

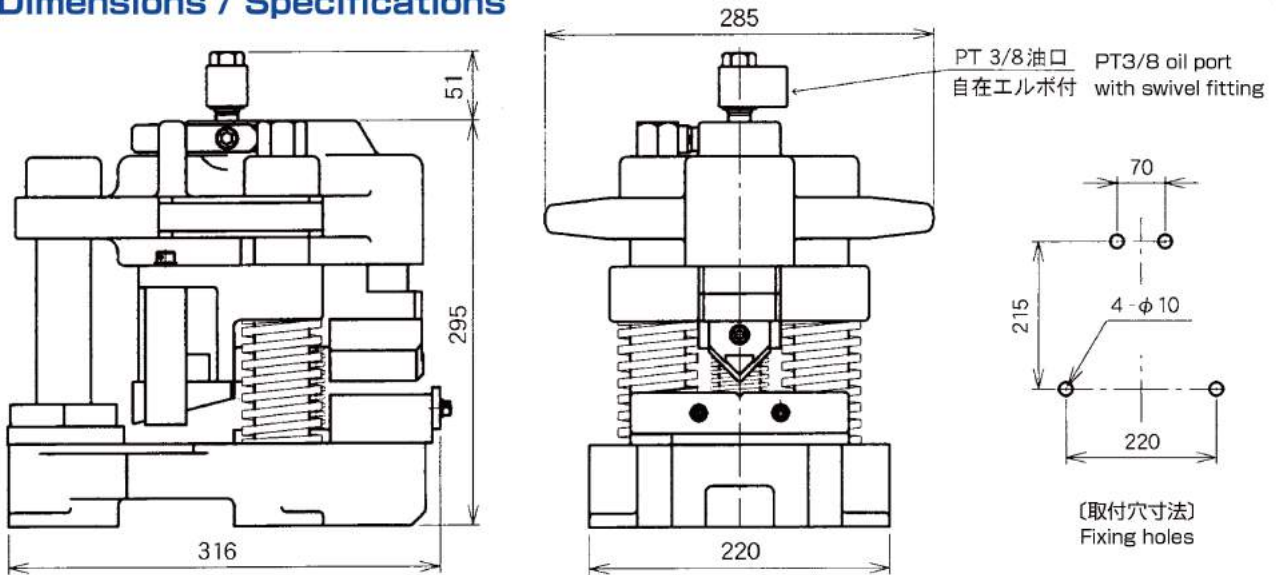

Model	Capacity (mm)	Single-acting Ram		Stroke (mm)	Dim (mm)	Weight (kg)	Unit components
		bending	V notching				
FM-30	Steel & Stainless steel of 75 × 75 × 6	170kN	230kN	35	316 (L) × 220 (W) × 295 (H)	50	Forming unit, hydraulic pump and hose.

■ Dimensions / Specifications of pumps

● Model UP-35RH-FL

(mm)

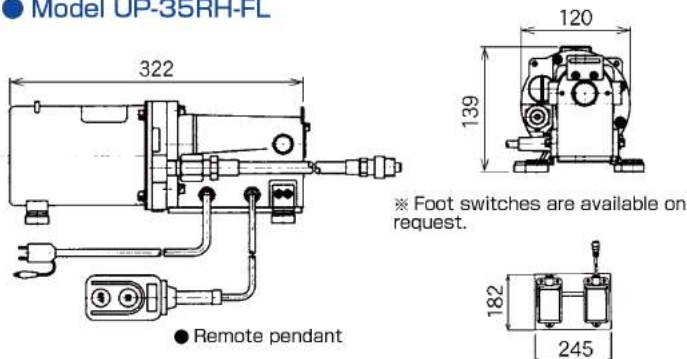

Pressure rating	70MPa (700kgf/cm ²)	
Flow rate	2.0ℓ/min (min/1st stage)	0.2ℓ/min (min/2st stage)
Tank usable oil	0.8 ℓ	
Electric motor	100V、350W (50 / 60Hz)	
Dimensions	282 (L) × 111 (W) × 140 (H) mm	
Weight(with oil)	7.5kg	

● Model UP-45SVG-F

(mm)

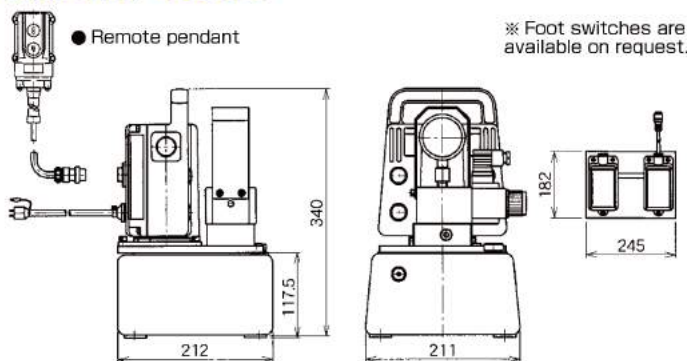

Pressure rating	70MPa (700kgf/cm ²)	
Flow rate	2.5ℓ/min (min/1st stage)	0.35ℓ/min (min/2st stage)
Tank usable oil	2.0 ℓ	
Electric motor	100V、450W (50 / 60Hz)	
Dimensions	212 (L) × 212 (W) × 340 (H) mm	
Weight(with oil)	17.2kg	

Nittoh Zohki Co.,Ltd.

Sales office :

2-4-10 Kamezawa, Sumida-ku, Tokyo 130-0014 Japan
Tel. +81-3-3625-6551 Fax.+81-3-3625-6553

Factory :

585 Takashi, Mobara-shi, Chiba-Ken 297-0029 Japan
<http://www.nittohpower.jp>